

Slide & Fold Doors

Bring the outdoors in with Quantum's **Slide & Fold** door system. This unique system joins multiple door panels (up to 8 panels in each direction) with a sliding and folding mechanism and delivers tremendous flexibility for large scale openings.

When closed, **Slide & Fold** doors appear to be a wall of beautiful hinged doors. Fold open the doors and the wall virtually disappears leaving an unobstructed opening capable of spanning over 64 feet. Each door can be specified to slide and fold. For easy access, an independent hinged door can be integrated at multiple locations depending on configuration.

Slide & Fold systems are configurable in many combinations including corner units requiring no center support. Our systems are top hung and may be specified as in-swing and out-swing. Optional heavy duty, multi-point locking hardware brings it all together for ease of opening, folding and sliding.

For more information on oversized **Slide & Fold** doors please contact your Quantum Representative.



Seattle, WA
Arellano|Christofides Architects | Constructive Energy
Michael Moore Photography



Salem, SC
Jeremiah Eck Architects



Edina, MN
RKD Architects
Jill Greer Photography

For more information please contact your Quantum Representative



Slide & Fold Doors

4 Panel Slide & Fold

3 left, 1 right (431)

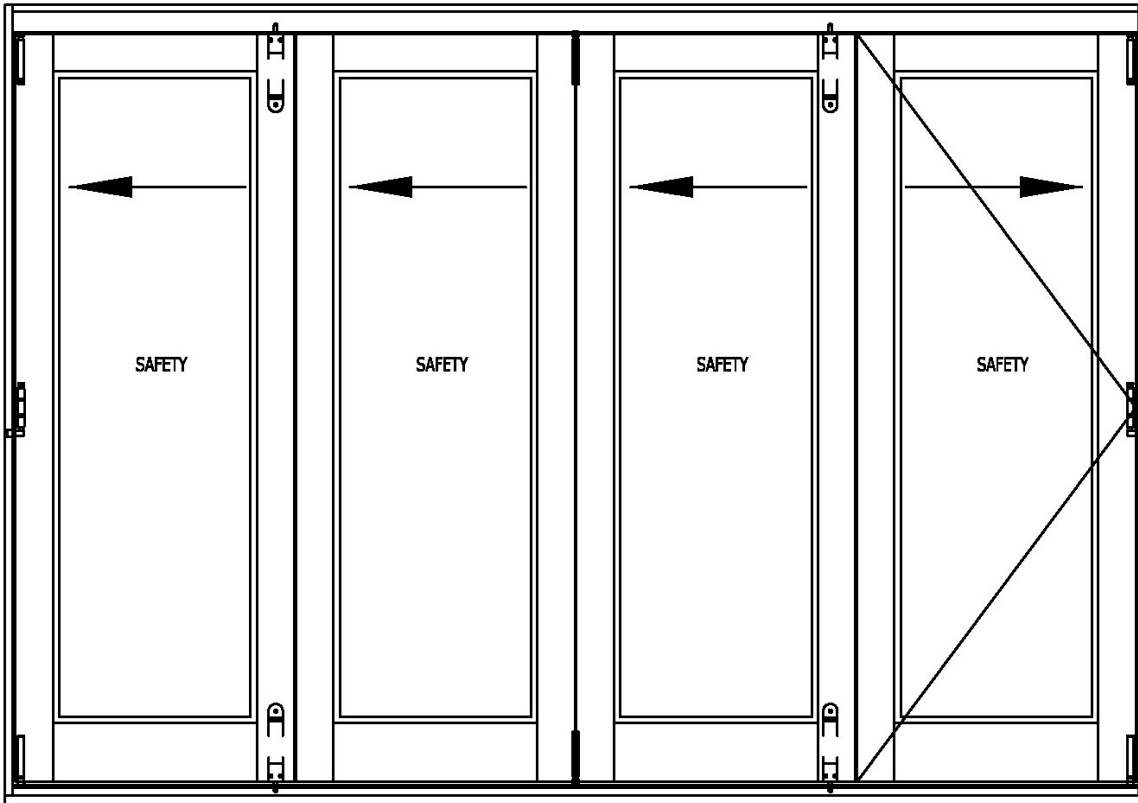

For more information please contact your Quantum Representative



Slide & Fold Doors

Configurations

2 left (220)

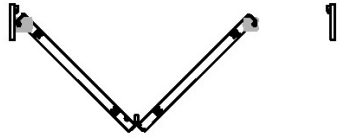

2 left, 1 right (321)



3 left (330)

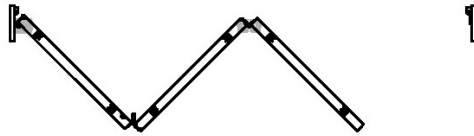

2 left, 2 right (422)



2 left (220)



4 left (440)



3 left, 2 right (532)



4 left, 1 right (541)

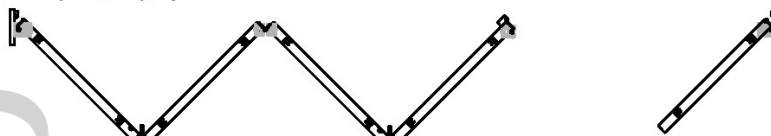

Slide & Fold Doors

Configurations

4 left, 1 right (541)

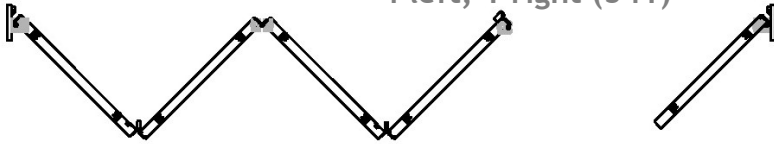

5 left (550)

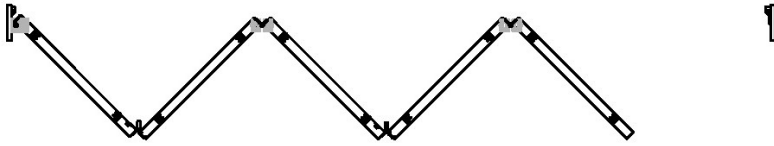

3 left, 3 right (633)

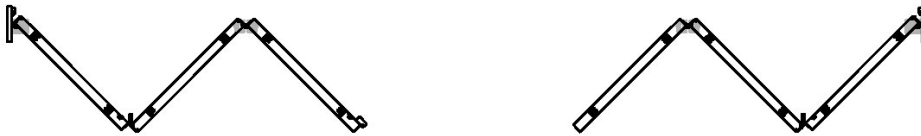

4 left, 2 right (642)



5 left, 1 right (651)

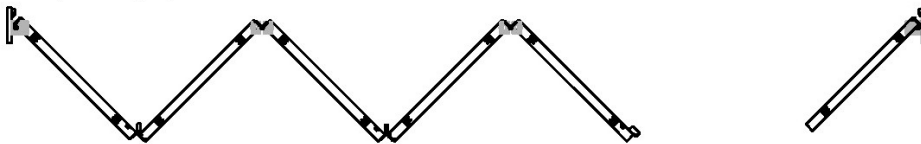

6 left (660)



4 left, 3 right (743)



5 left, 2 right (752)



For more information please contact your Quantum Representative



Slide & Fold Doors

Configurations

6 left, 1 right (761)

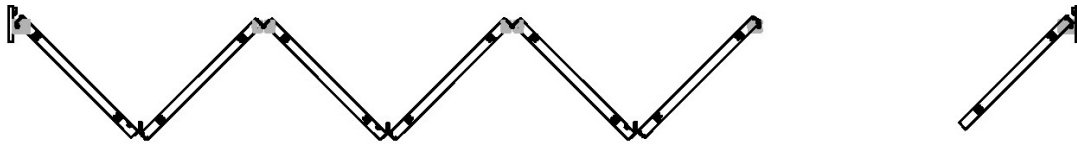

7 left (770)



4 left, 4 right (844)



5 left, 3 right (853)

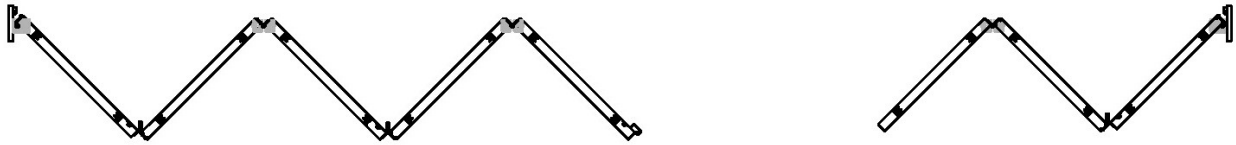

6 left, 2 right (862)

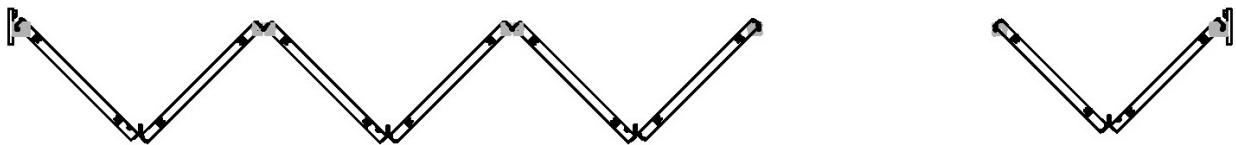

7 left, 1 right (871)

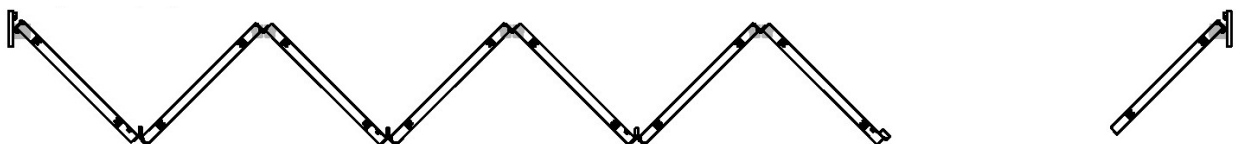

8 left (880)

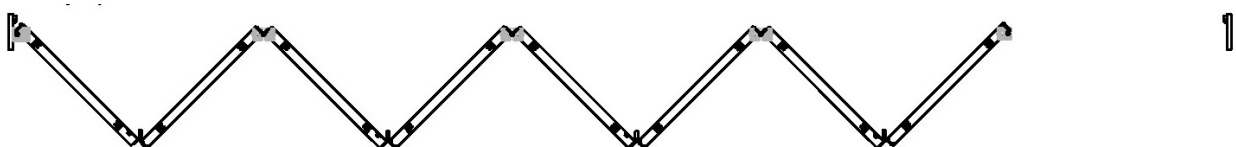

For more information please contact your Quantum Representative

Slide & Fold Doors

Standard Details

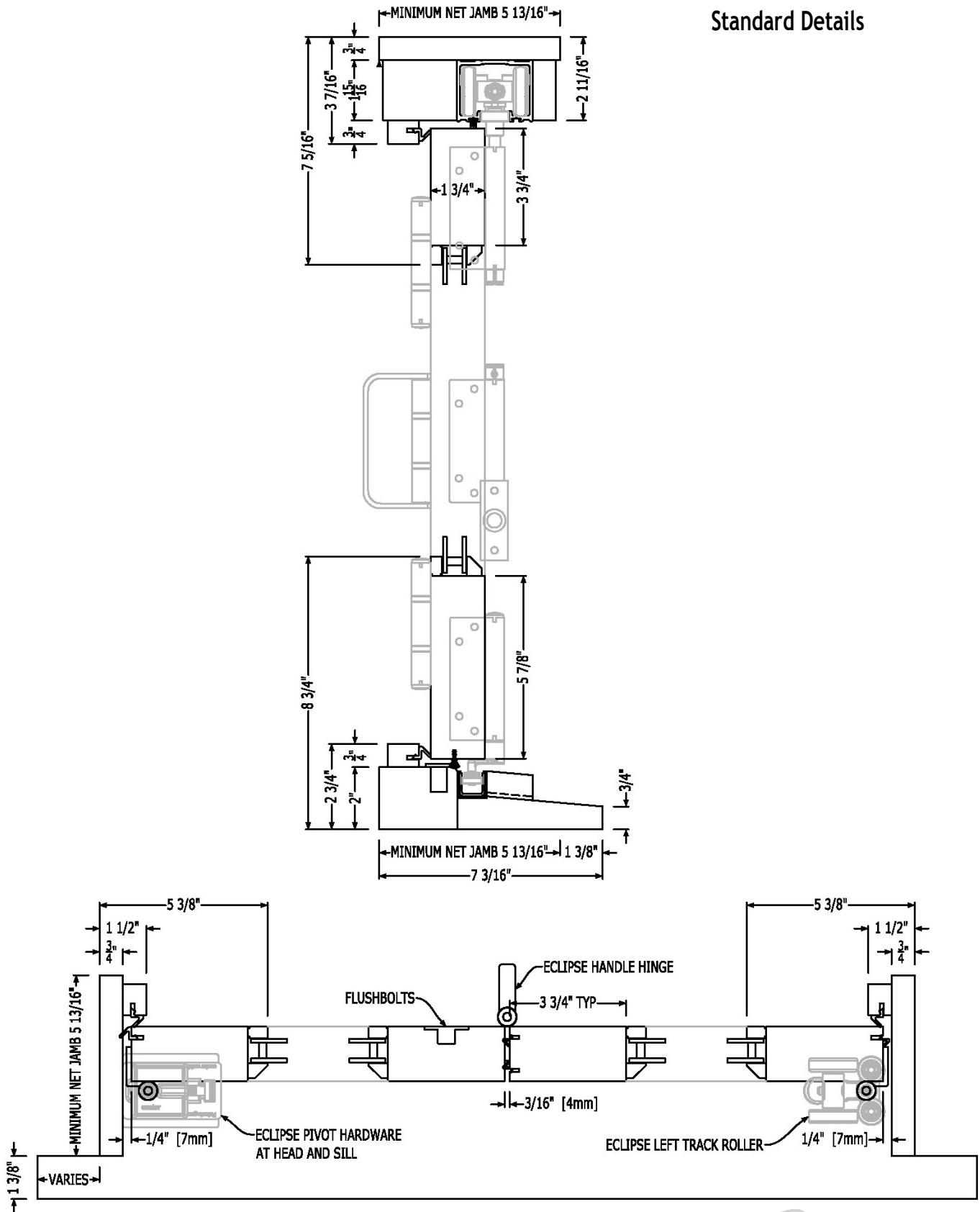

For more information please contact your Quantum Representative



Slide & Fold Doors

Outswing Sill Options

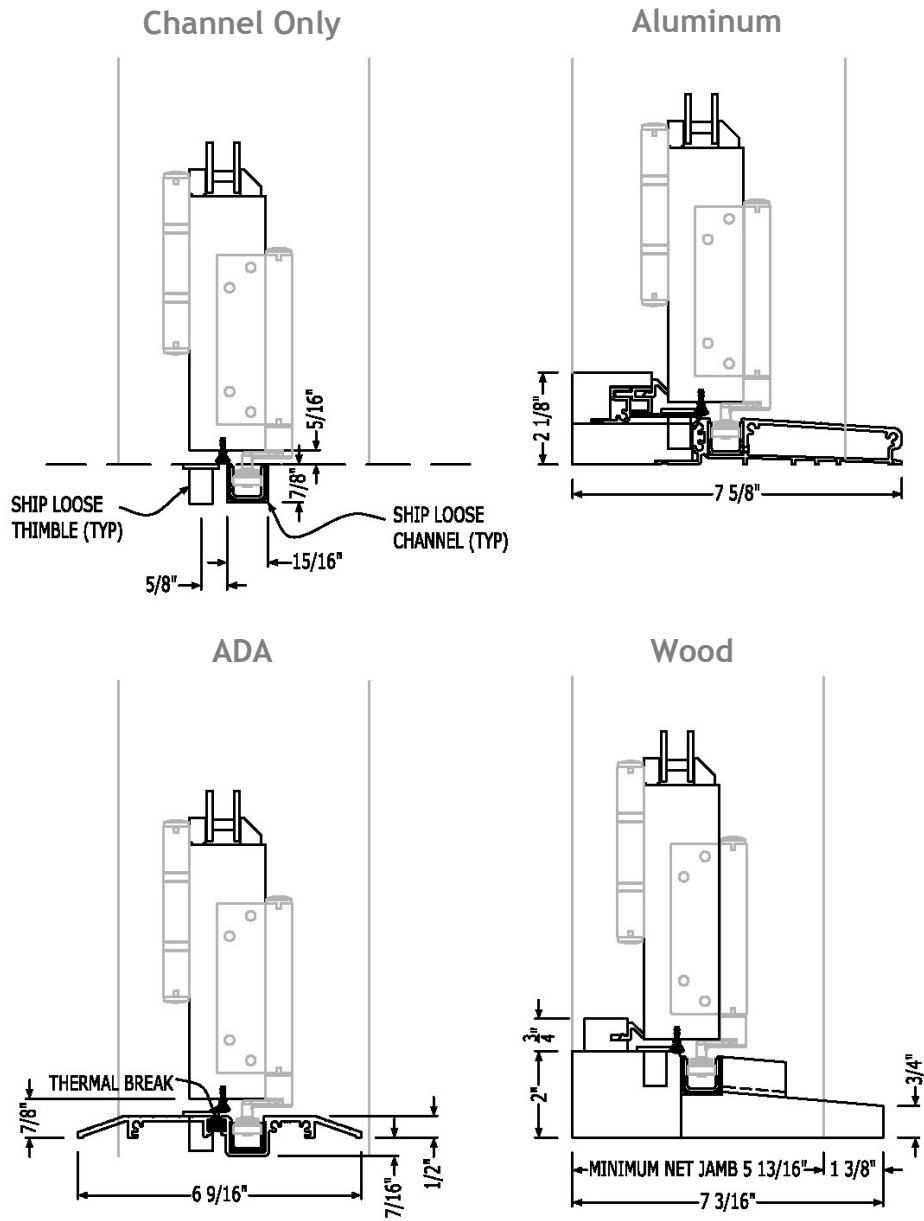

For more information please contact your Quantum Representative

Slide & Fold Doors

Inswing Sill Options

Channel Only

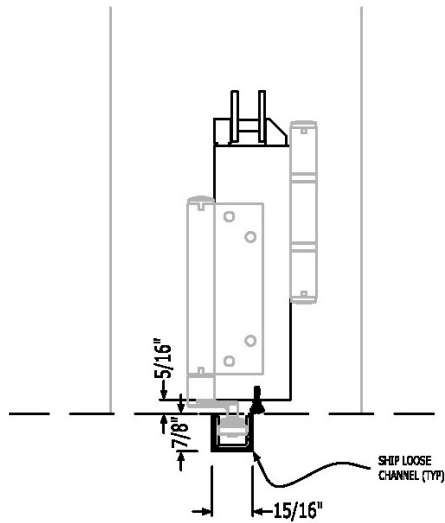

ADA

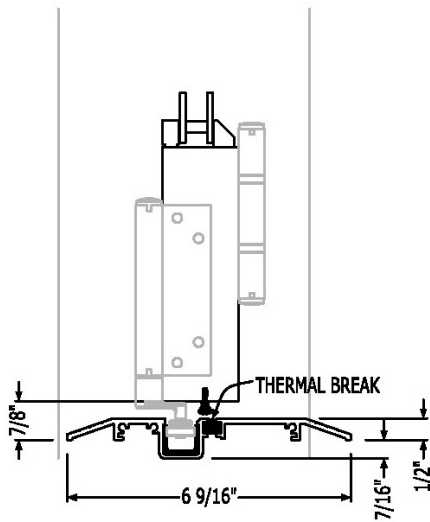

Wood

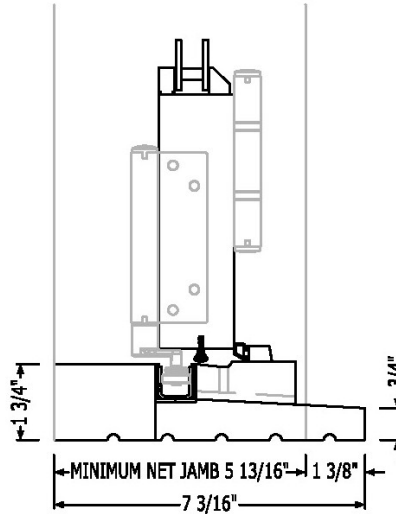

For more information please contact your Quantum Representative

