

## Hinged and Pivot Doors

At Quantum, we understand the complexities of building doors that are strong, secure, and exceptionally well crafted. Not only are Quantum doors beautiful in appearance, their quality is tangible with every touch or operation.

Quantum's **Hinged and Pivot** doors utilize stile and rail construction. Whether building with engineered Douglas Fir core or using optional slab construction, Quantum's **Hinged and Pivot** doors are unsurpassed in appearance, performance and durability.

Quantum's doors are available in many designs, configurations and operations. We build pivot doors, single and double hinged doors, solid panel, raised panel, dutch doors and any variation in between. We offer a wide variety of species as well as operable sidelites, custom glazing and true divided lites. We can accommodate a range of hardware options, along with a choice of high performance teak, sapele or aluminum sills.

In applications where a clad product may be more desirable, we have added **Quantum Clad** to our list of door options. Ask your Quantum Representative about the available styles, colors and pricing.

Quantum builds the same quality into our interiors doors and offers them in all of our finish options, including raw, primed, painted or clear coat. Whether you are looking for a painted finish, Clear Vertical Grain (CVG) Douglas Fir with raised panels, or an exotic hardwood, Quantum will build anything you can imagine.



Mercer Island, WA  
Heliotrope Architects  
Alex Hayden Photography

### Styles

- Flat & Raised Panels
- Tongue & Groove
- Full Glass
- Custom Designs

### Options

- True Divided Lites
- Transoms
- Sidelites
- Wood Species
- Glazing



Lake Oswego, OR  
Reveal Architecture + Interiors  
Laurie Black Photography



Austin, TX  
William VanReed Furbush  
Paul Bardagiy Photography



Folsom, CA  
GRA Architects

For more information please contact your Quantum Representative



# Hinged and Pivot Doors

## Outswing Single

Shown with Double Rabbet Jamb

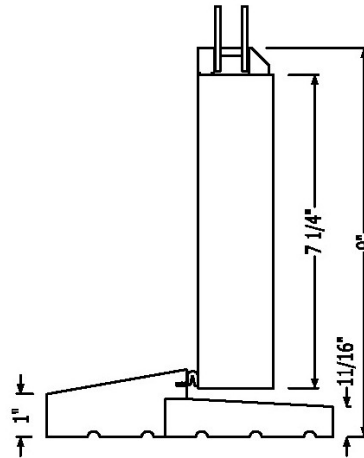
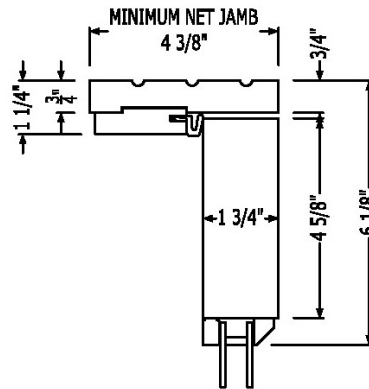
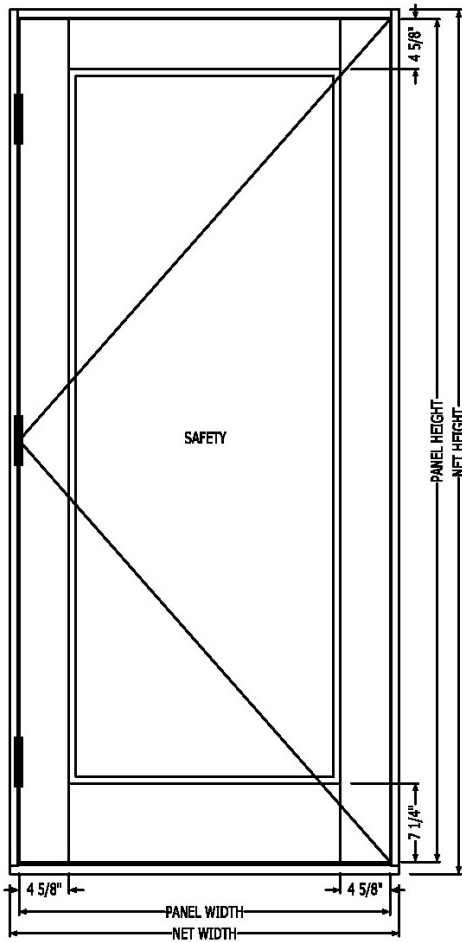

OUTSWING BUMPER SILL

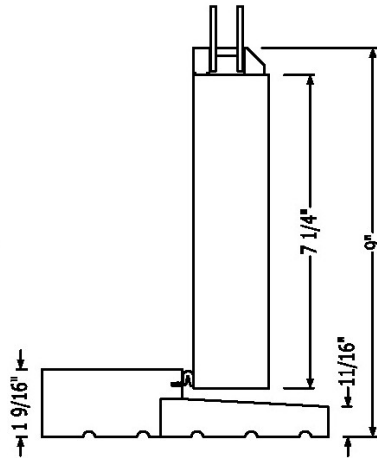

OPTIONAL FLAT BUMPER SILL

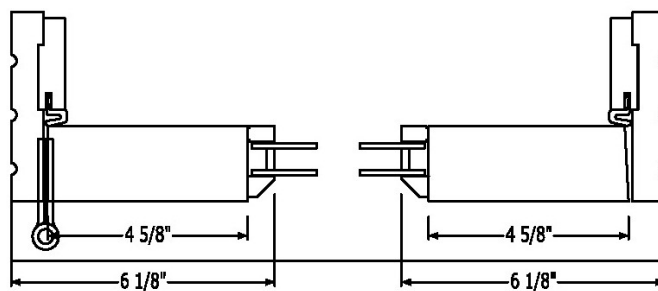

For more information please contact your Quantum Representative



# Hinged and Pivot Doors

## Inswing Single

Shown with Single Rabbet Jambs

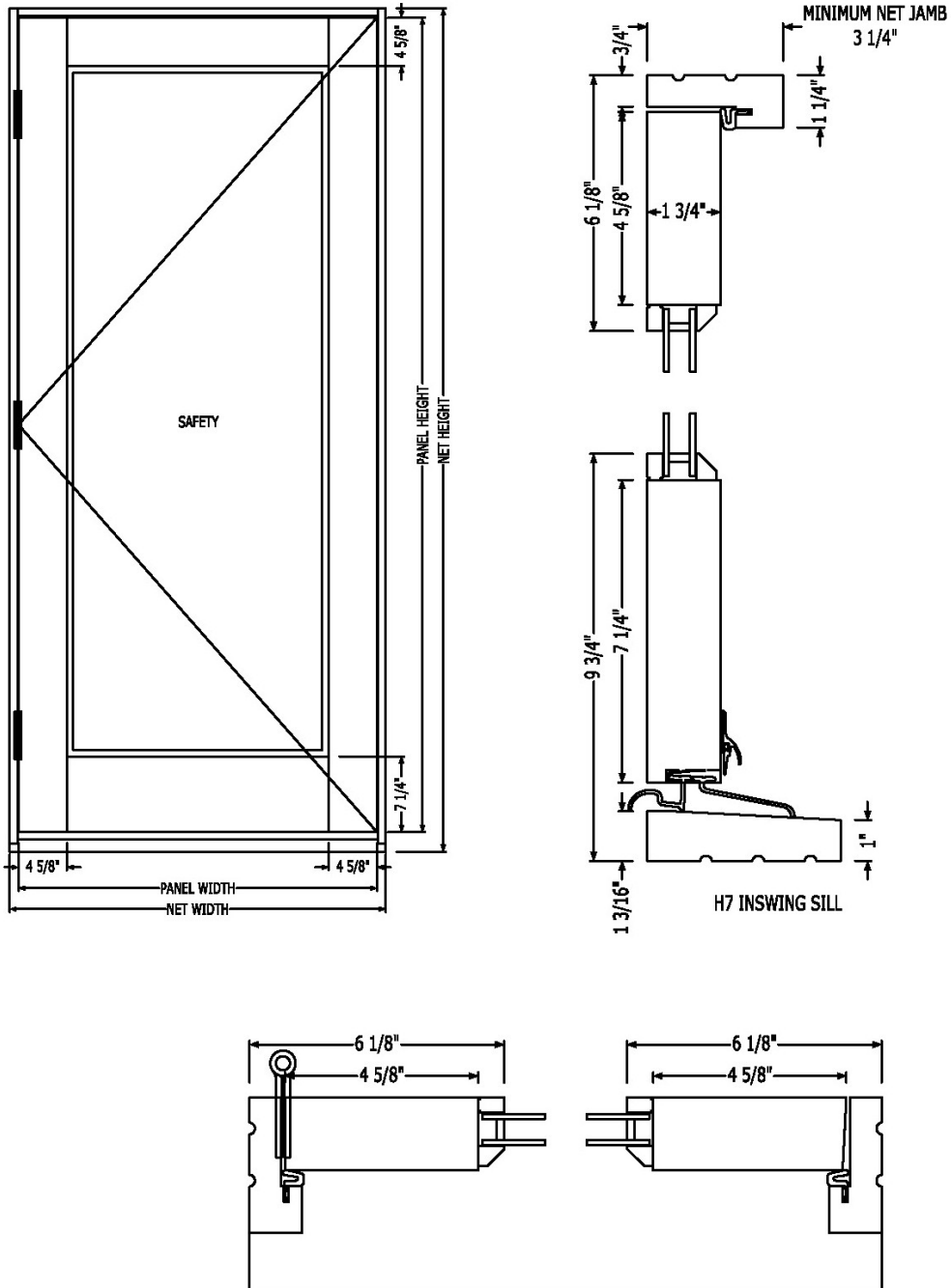

For more information please contact your Quantum Representative

# Hinged and Pivot Doors

## Inswing Double

Shown Double Hung with Double Rabbet Jamb and Screens

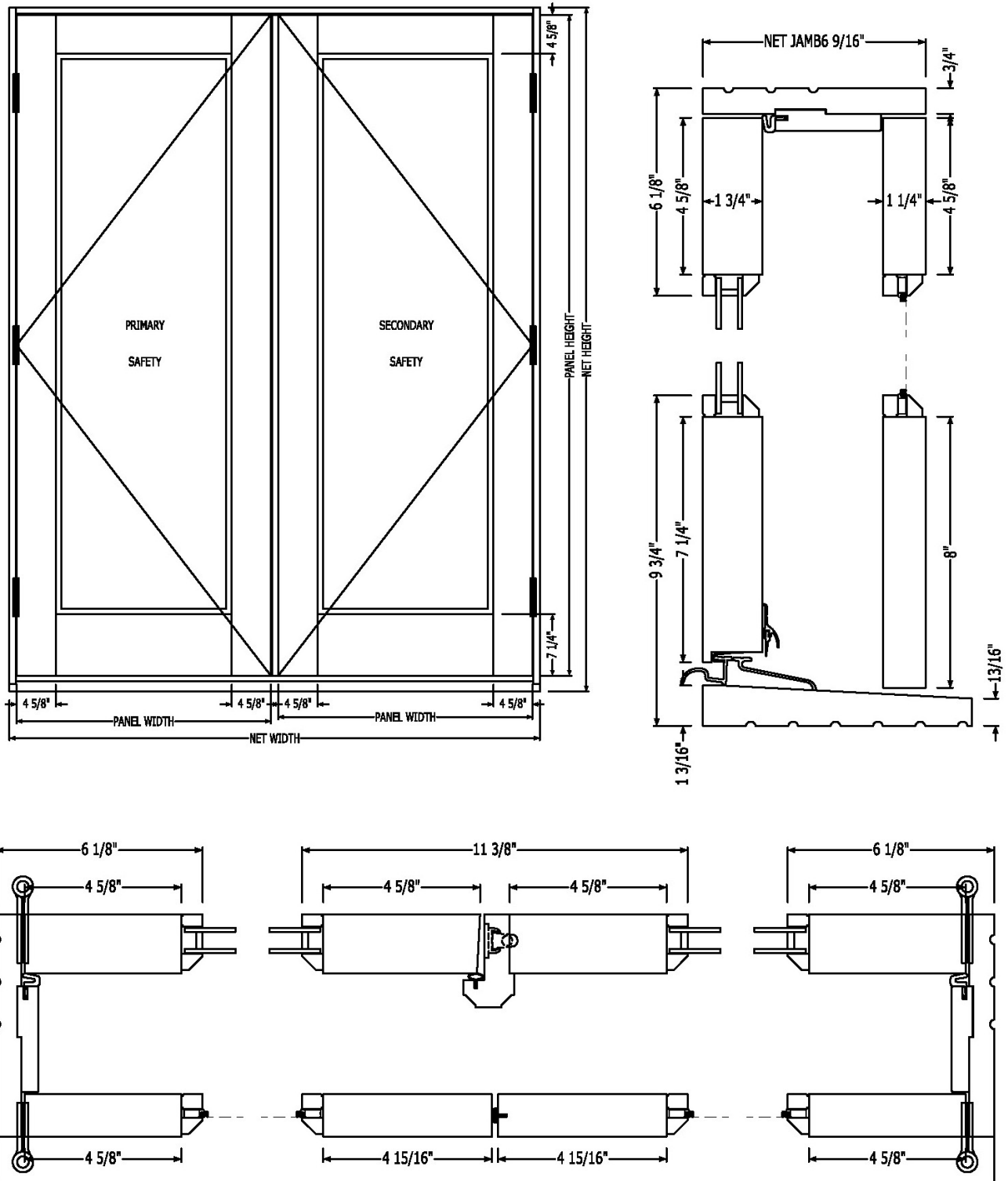

For more information please contact your Quantum Representative



# Hinged and Pivot Doors

## Outswing Double

Shown Double Hung with Double Rabbet Jamb

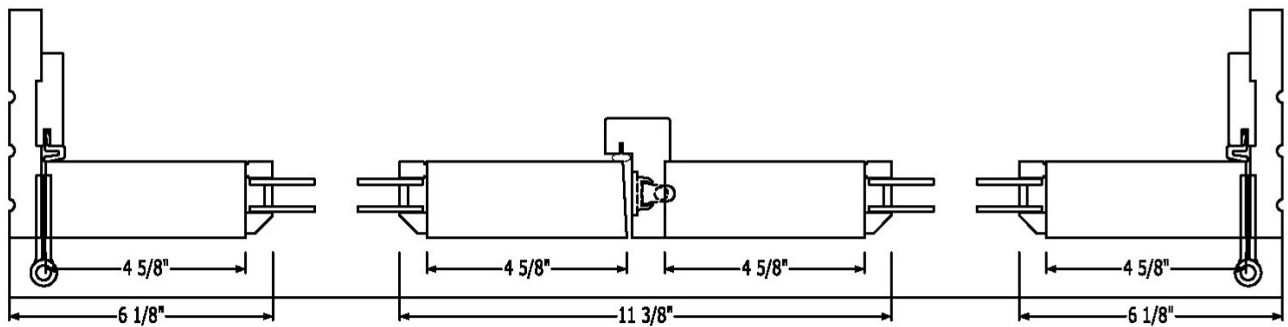
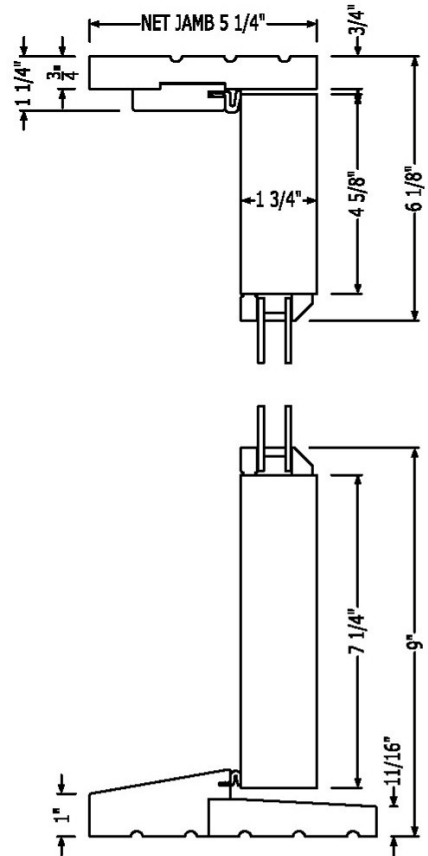
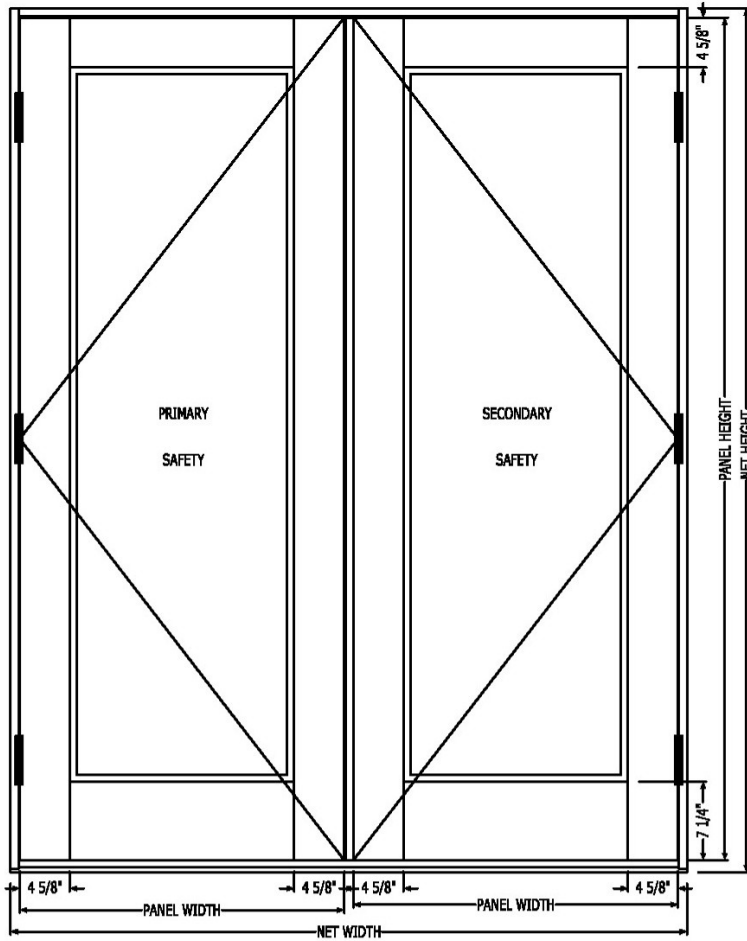

For more information please contact your Quantum Representative

# Hinged and Pivot Doors

## Pivot Door

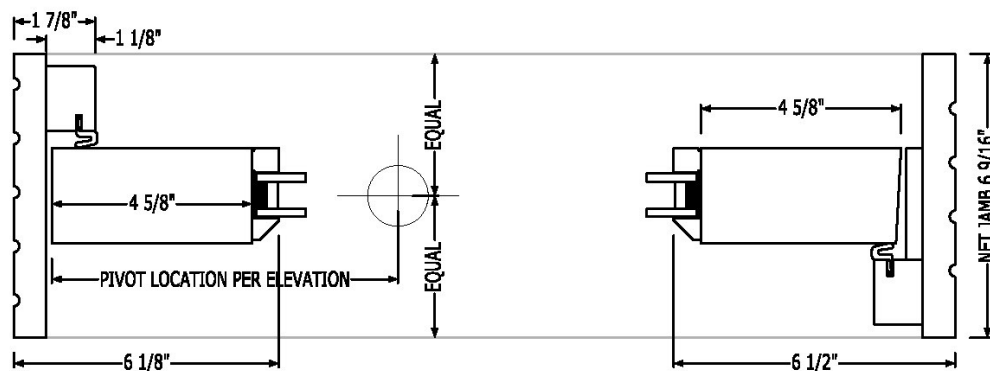
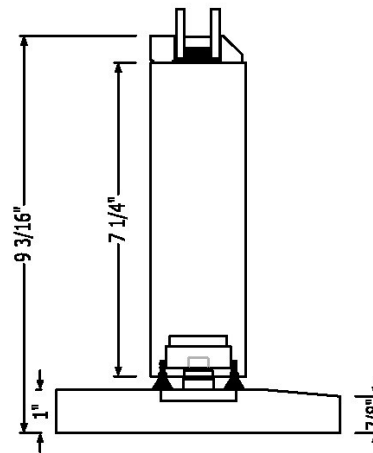
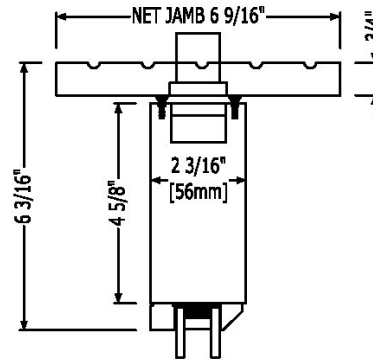
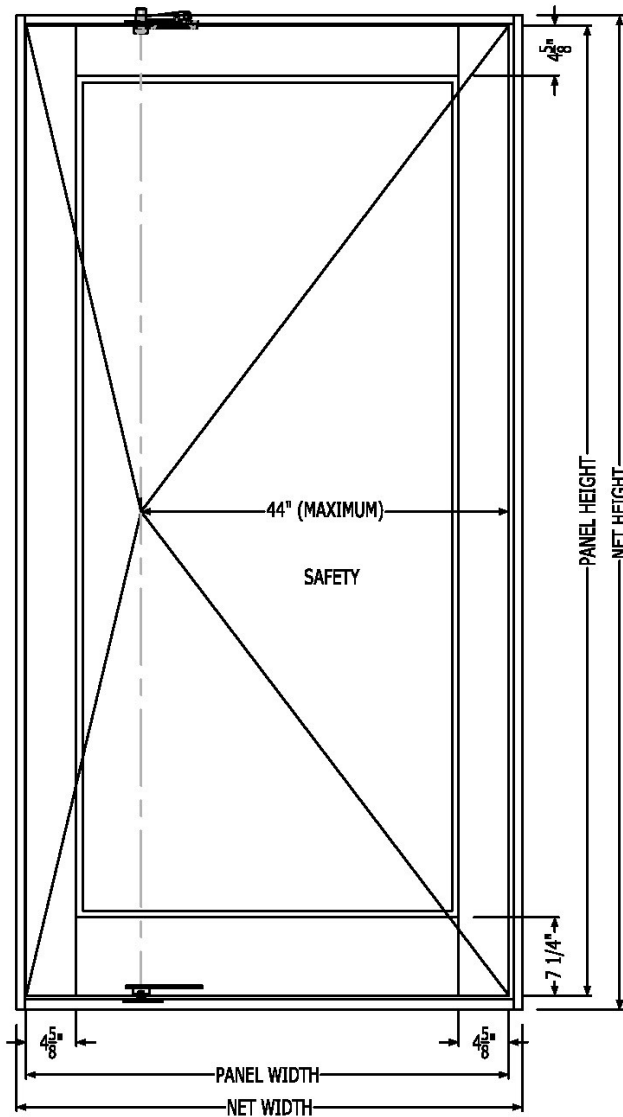

For more information please contact your Quantum Representative



# Hinged and Pivot Doors

**Quantum Drawings are Exterior Views**  
**Door Handing is always determine from the Outside (Key Side)**

The outside of an exterior door is the:

- Exterior Side
- Key Side

The outside of an interior door is the:

- Hall Side
- Key Side

Addition terms for pairs of doors:

Double-Active

- No Astragal
- Swing Inward

Double-Active Reverse

- No Astragal
- Swing Outward

## Single Doors

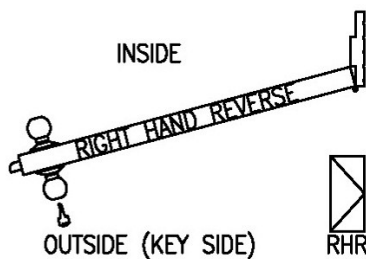
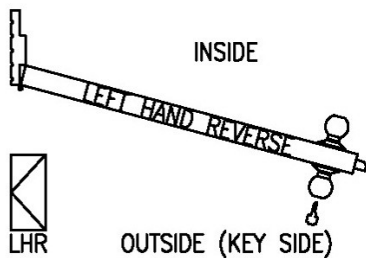
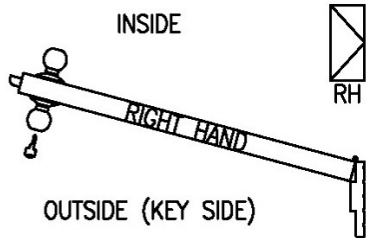
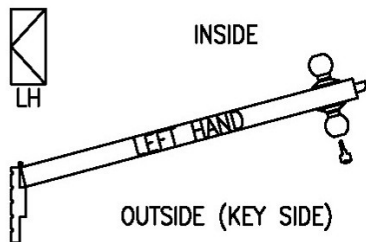

## Pairs of Doors

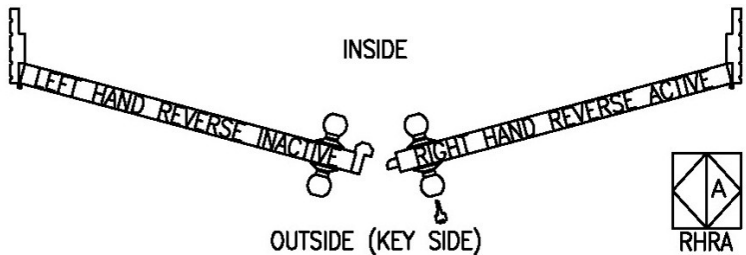
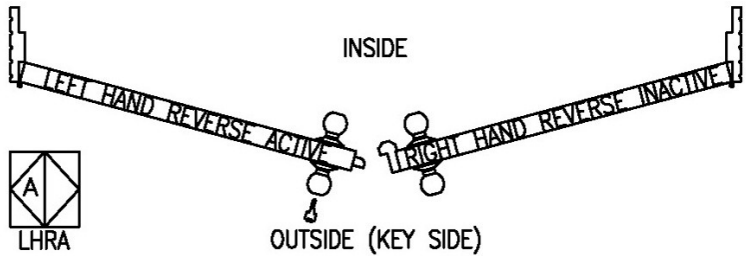
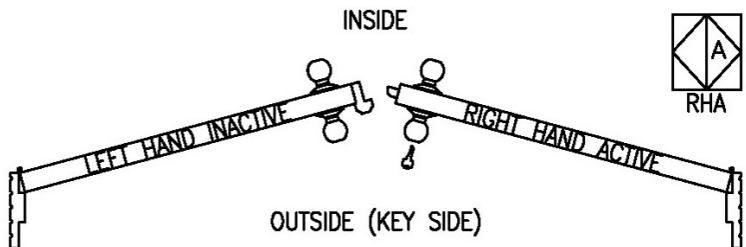
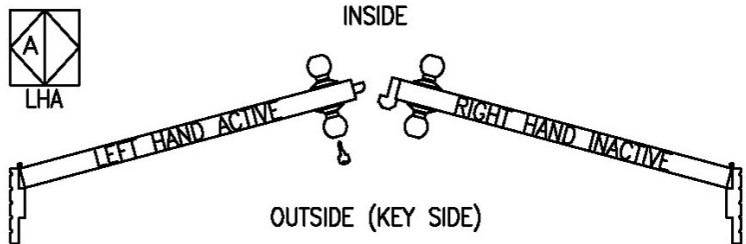

For more information please contact your Quantum Representative