

Pacific Series Folding Door

Overview

Quantum has long offered the elegant and versatile Slide/Fold Door. And, now due to an innovative hardware system we are pleased to offer a similarly functioning yet value priced folding wall system—introducing the Pacific Series Folding Door.

Imagine a clear span 64 feet wide. It's possible with the Pacific Series Folding Door. Up to eight panels in each direction can be installed opening up amazing living spaces.

The rugged hardware system makes it possible. Engineered to withstand heavy duty use in all kinds of environments, the stainless steel hardware is virtually maintenance free even in harsh coastal areas.

Quantum's handcrafted wood components deliver the beauty and the hardware delivers a smooth operation with precision roller bearing mechanisms. Available for both doors and windows, the Pacific Series Folding Door opens up exciting new design opportunities to seamlessly blend indoor and outdoor spaces. Infinite possibilities exist for inswing or outswing configurations. Corner units are offered as well. Built-in security features are standard.

All panels are the same size resulting in manufacturing efficiencies. Weather-stripping in the opening and between the doors ensures a tight seal. Simple adjustment that may be required are easy to make with easy access. Take a closer look at the Quantum Pacific Series Folding Door.



Bottom Guide



Flush Bolt



Typical Hardware

Specification Highlights

Maximum Panel Width	39"
Maximum Panel Height	120"
Maximum Panel Weight	176 lbs.
Stile Width	3-3/4"
Hardware:	
Hinges & Pulls	Stainless Brushed Finish, Bright Polished Brass, Oil Rubbed Bronze US-10B
Hardware:	
Head track, U-channel, Aluminum Bumper Sill, Flush Bolts	Clear and Dark Anodized Aluminum



Pacific Series Folding Door Sample Configurations

PANEL CONFIGURATION: 321 (2L1R)

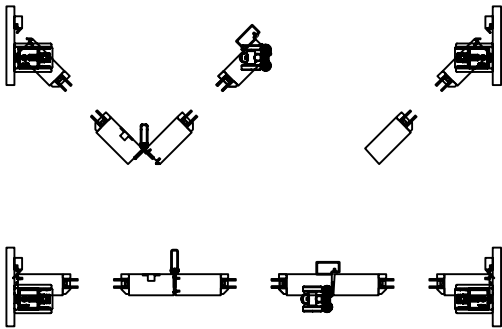

There is an infinite number of door configurations from which to choose. Your Quantum Representative will be able to offer the right solution to meet your objective.

PANEL CONFIGURATION: 422 (2L2R)

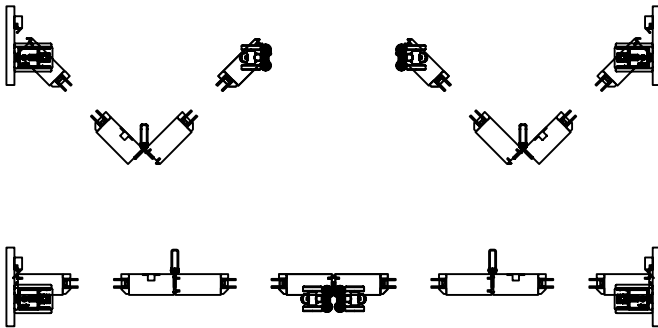

PANEL CONFIGURATION: 431 (3L1R)

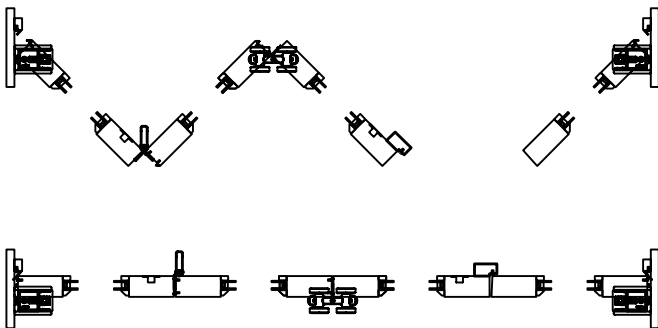

PANEL CONFIGURATION: 844 (4L4R)

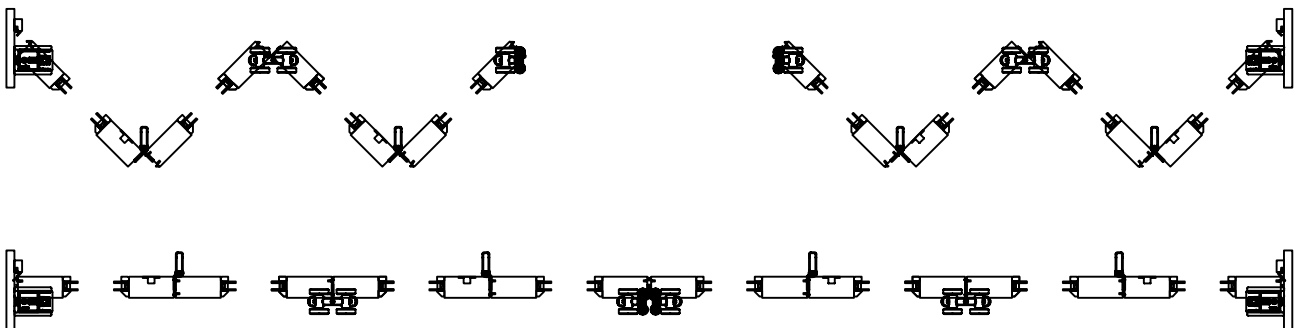

Pacific Series Folding Door Side Jamb

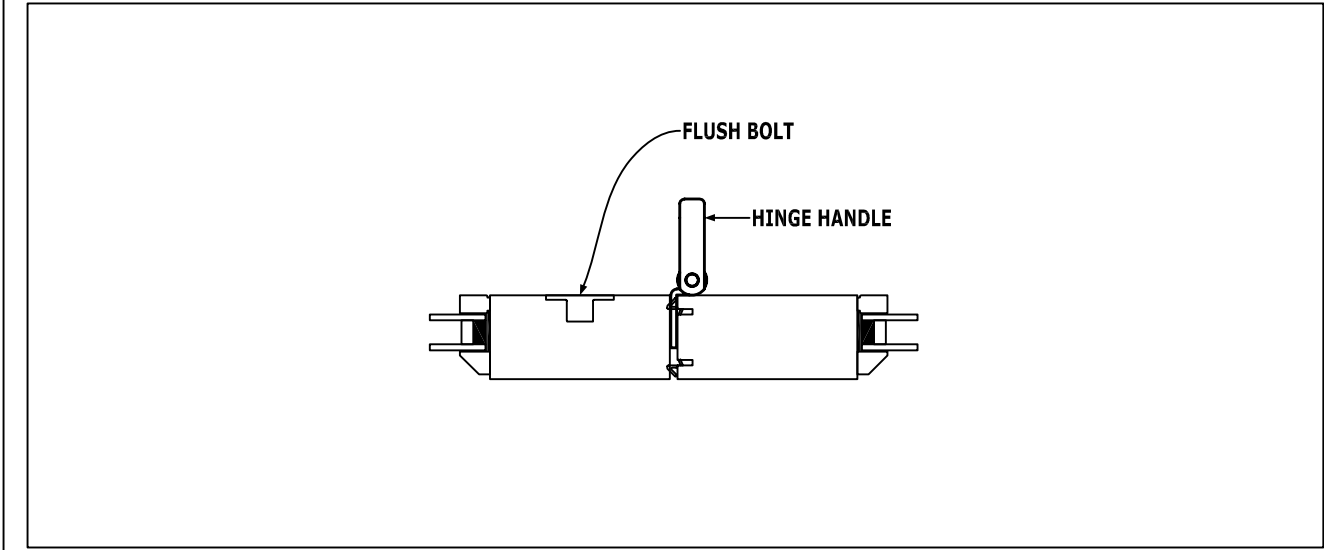
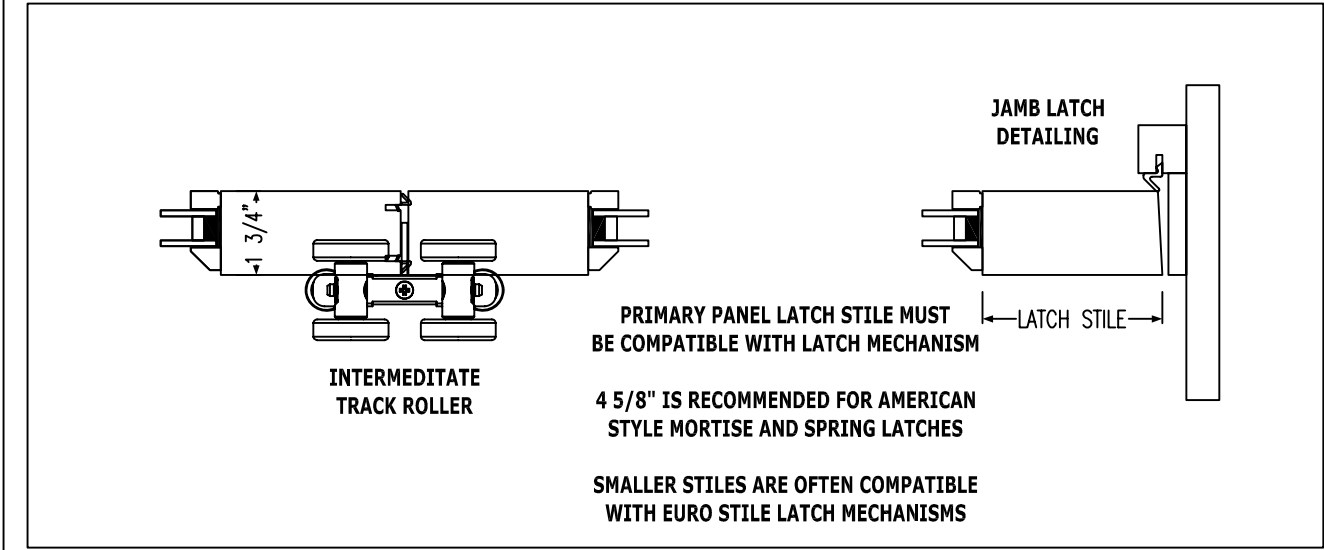
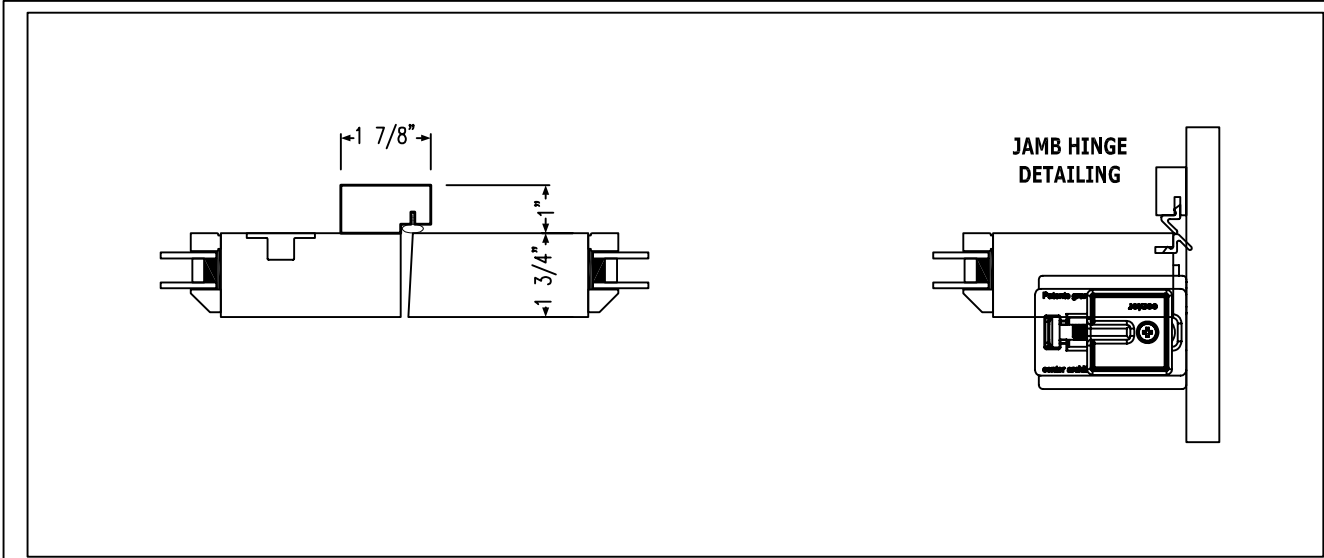

Pacific Series Folding Door Head & Sill

