

Quantum's focus on impeccable alignment and attention to the details ensures interior and exterior wood doors are crafted to specification. Classic stile and rail construction from premium woods is at the heart of every handcrafted door Quantum builds.

One-of-a-kind designs are our specialty. Transoms and sidelites are available to complete the design.

Doors Styles

Single and Double Hinged Doors

Flat and Raised Panels

Glass

Tongue and Groove

Arches and Angles

Dutch

Euro Series

Lift/Slide

Slide/Fold

Pacific Series

Slide/Fold

Sliding

Sizes

Components and overall sizes may be customized to fit the design.

Wood and Finishes

Clear, vertical grain Douglas fir is our standard wood species. We have extensive experience manufacturing in many other popular and exotic species including salvaged, recycled and FSC certified woods. Consult your Quantum Representative for more information.

Dual Species

Quantum is an innovative leader in the development of dual species profiles featuring one species on the exterior and another on the interior producing dramatic results that meet design criteria.

Engineered Door Products

Our cost-efficient engineered door products are designed to maximize appearance and improve stability. This approach to stile and rail construction is ideally suited to dual species construction.

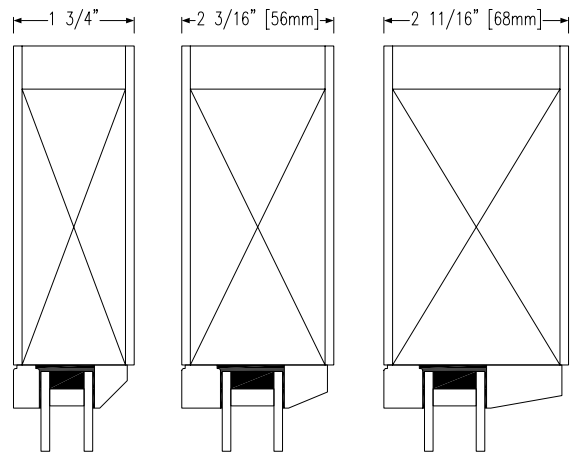

Our stile and rail construction is second to none and features doweled connections for tight fitting joints.

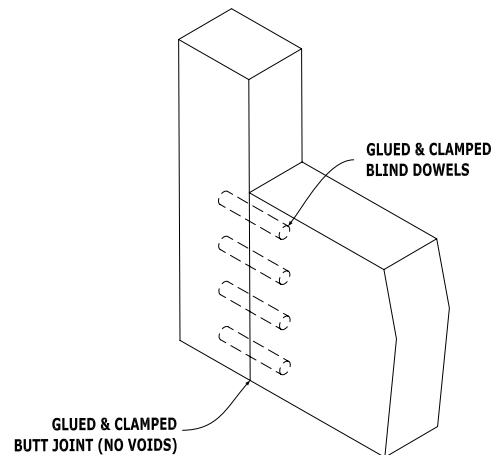

Glazing

Dual-sealed, insulating glass units are standard and manufactured in-house with superior quality control standards. Glass options are many, including art and specialty glasses.

Door Overview

True Divided Lites

Quantum is known for true divided lites. We take the utmost pride in building TDLs and can handle just about any design you can conceive. True divided lites can be designed for all of our doors, transoms and sidelites. Sightlines are extremely important and we take extra care to ensure the millwork and glass are aligned to achieve precise sightlines.

Transoms & Sidelites

Transoms and sidelites will often complete the door system and Quantum offers complete flexibility when it comes to matching specific design requirements. Consult your Quantum Representative for joining options.

Screens

Wood frame screen doors are available for all Quantum doors except the Slide/Fold and the Pacific Series Sliding Door. Automated screens that operate by remote control or are built in to home automation systems are available as well.

Finishing

Quantum simplifies the finishing process on the job site by offering interior and exterior primer and/or finish coats. These steps provide an extra measure of assurance that the entire job will look the same.

A factory-applied primer is an available option with the finish coat to be applied immediately after delivery to the job site. We recommend you contact a finishing consultant in your area for help in determining the best finish for your climate.

Factory-applied finishes may be specified by the architect. Quantum offers several finish options including paint, stains, translucent breathable protection, and painted finishes engineered to stand up to the harshest environmental elements.



Door Overview Astragals

